

04-02

Axis Designation

In every CNC program, the designation of machine axes is extremely critical. The three exercises in this project show several variations on this subject. The objective is to identify the key elements of each individual project.

Project 04-02A

In the illustration on the right, fill-in the *names* (designations/identifications) of axes in the nine open fields

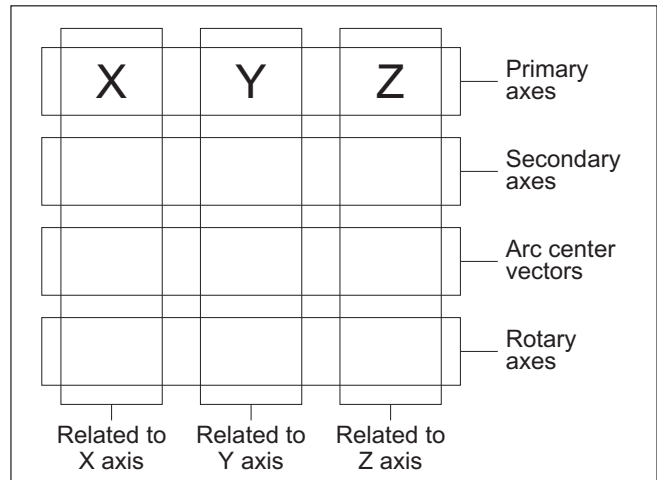

Project 04-02B

In the illustration on the right, fill-in the three large boxes with *descriptions of planes* as well as the three small boxes with *definitions of rotary axes*

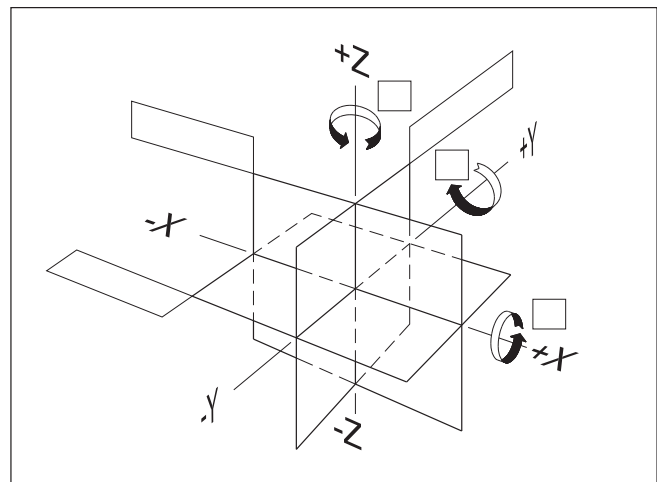

Project 04-02C

In this third project, the objective is to fill-in the eight boxes with the *axis name* and the *axis orientation* (positive or negative), as indicated in each illustration

